

Temposonics®

Magnetostrictive Linear-Position Sensors



M-Series Mobile Equipment Sensor
Model MH
Digital Output / Scaled PWM

551119 A

Product Specification

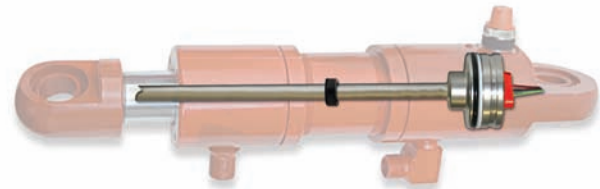
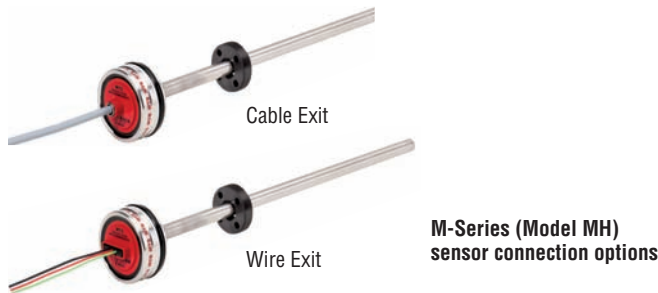

M-Series (Model MH) with digital output (sensor shown in cylinder application)

Features

- Linear, Absolute Position Sensors
- Non-contact Sensor Technology
- Superior Accuracy: Linearity < +/- 0.04% F.S.
- Repeatability: < ± 0.005% F.S.
- Compact Design for Embedded Cylinder Applications
- No External Electronics
- Digital Output: Selectable Frequency; 50 Hz to 500 Hz Scaling (PWM); 5% - 95% to 25% - 75%
- Sensor Stroke Length: 50 mm (1.97 in.) - 2000 mm (79 in.)
- Power Supply: 12/24 Vdc
- Shock Rating: 100 g (single hit) / IEC 68-2-27
- Vibration Rating: 25 g / 10-2000 Hz / IEC 68-2-6

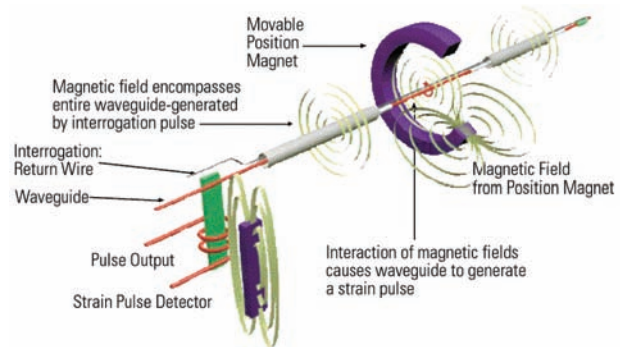

Product overview

Today's buyers are more concerned with greater productivity, lower overall operating costs and cost of ownership. Temposonics M-Series Mobile Equipment sensors help lower overall costs by increasing safety and versatility, increasing reliability and reducing service costs. Temposonics Mobile Equipment sensors are designed specifically for position sensing applications in rugged environments typically encountered by construction, agriculture and other off-highway machinery. All Temposonics Mobile Equipment sensors utilize magnetostrictive technology.

The M-Series, Model MH sensor with digital output features scalable PWM. This Model MH sensor is one of the latest compact stainless-steel position sensor specifically designed for use in welded and tie-rod style cylinders, or any space limited cylinder application. The M-Series Model MH sensor is an ideal choice for a wide range of standard hydraulic cylinders with diameters of 50 mm (1.97 in.) or larger.

The extremely rugged model MH sensor consists of the following main components:

1. The sensor head; A robust housing with built-in electronics.
2. The pressure-proof sensor pipe; The sensor pipe houses and protects the internal sensing element.
3. The position magnet; The magnet is mounted on the piston, during operation it travels along the stationary sensor tube. This sensor system is "non-contact" by design.

Benefits of magnetostrictive sensing

Temposonics linear-position sensors use the time based magnetostrictive position sensing principle developed by MTS. Within the sensing element, a sonic strain pulse is induced in a specially designed magnetostrictive waveguide by the momentary interaction of two magnetic fields. One field comes from a movable permanent magnet that passes along the outside of the sensor. The other field comes from an "interrogation" current pulse applied along the waveguide. The resulting strain pulse travels at ultrasonic speed along the waveguide and is detected at the head of the sensing element.

The position of the magnet is determined with high precision and speed by accurately measuring the elapsed time between the application of the interrogation pulse and the arrival of the resulting strain pulse with a high-speed counter. Elapsed time is used to determine the permanent magnet position which provides an absolute position reading that never requires recalibration or re-homing after a power loss. Non-contact sensing eliminates wear, and guarantees the best durability and output repeatability.

All specifications are subject to change. Contact MTS for specifications and engineering drawings that are critical to your application. Drawings contained in this document are for reference only. Go to www.mtssensors.com for the latest support documentation.

M-Series Model MH Digital Sensor product specifications and dimensions

Temposonics Model MH high-pressure compact sensor

M-Series sensors were designed with the “mobile” world in mind, and have been validated in the field by customers worldwide. Performance is second-to-none; high accuracy, repeatability, 200 V/m EMI, and position output.

Ruggedness is “designed in”; 100 g shock and 25 g vibration rating. Cable and wire options are sized for direct connection to industry proven connectors. The model MH sensor is fully sealed and when embedded in a cylinder provides a long operating life.

Parameters	Specifications
Measured variations:	Displacement
Resolution:	0.1 mm
Linearity, uncorrected:	$\pm 0.04\%$ F.S. minimum ± 0.100 mm (0.003 in.)
Repeatability:	$\pm 0.005\%$ F.S.
Update frequency:	> 488 Hz
Ripple:	< 0.05% F.S.
Stroke length:	50 mm - 2000 mm (79 in.) in 5 mm (0.19 in.) increments
Outputs:	Digital: Scaling (PWM): 5%-95%, 10%-90%, 15%-85%, 20%-80%, 25%-75% Frequency (Hz): 50, 60, 100, 200, 300, 400, 500
Operating temperature:	-40 °C (-40 °F) to 105 °C (221 °F) (sensor)
Dew point, humidity:	90% rel. humidity, no condensation
Sealing:	IP 67 (individual wires); IP 67 (cable exit)

Parameters	Specifications
Rod pressure ratings 10 mm (0.39 in.) rod:	350 bar (5076 psi) operating, 530 bar (7687 psi) peak pressure
7 mm (0.27 in.) rod:	300 bar (4351 psi) operating, 450 bar (6526 psi) peak pressure
Electrical connection:	Individual 4-wire (optional M12 connector) or Pigtailed PUR cable
Voltage input:	12/24 Vdc (10 to 32 Vdc)
EMI tests:	200 V/m: ISO 11452-5, ISO 14982, Agriculture and forest machines ISO 7637-0/1/2/3, Road vehicles DIN EN 50121-3-2:5/2001, Railway applications IEC 61000-6-1/2 - CE
Shock ratings 10 mm (0.39 in.) rod: 7 mm (0.27 in.) rod:	100 g (single hit) /IEC 68-2-27 100 g (single hit) /IEC 68-2-27
Vibration ratings 10 mm (0.39 in.) rod: 7 mm (0.27 in.) rod:	25 g RMS/ 10 - 2000 Hz/IEC 68-2-6 15 g RMS/ 10 - 2000 Hz/IEC 68-2-8
Current drain:	80 mA typical
Electrical isolation:	500 Vdc (DC ground to machine ground)
Polarity protection:	Up to -36 Vdc
Overvoltage protection:	Up to 36 Vdc
Sensor material:	Stainless steel 1.4301/AISI 304

Temposonics Model MH sensor dimensions

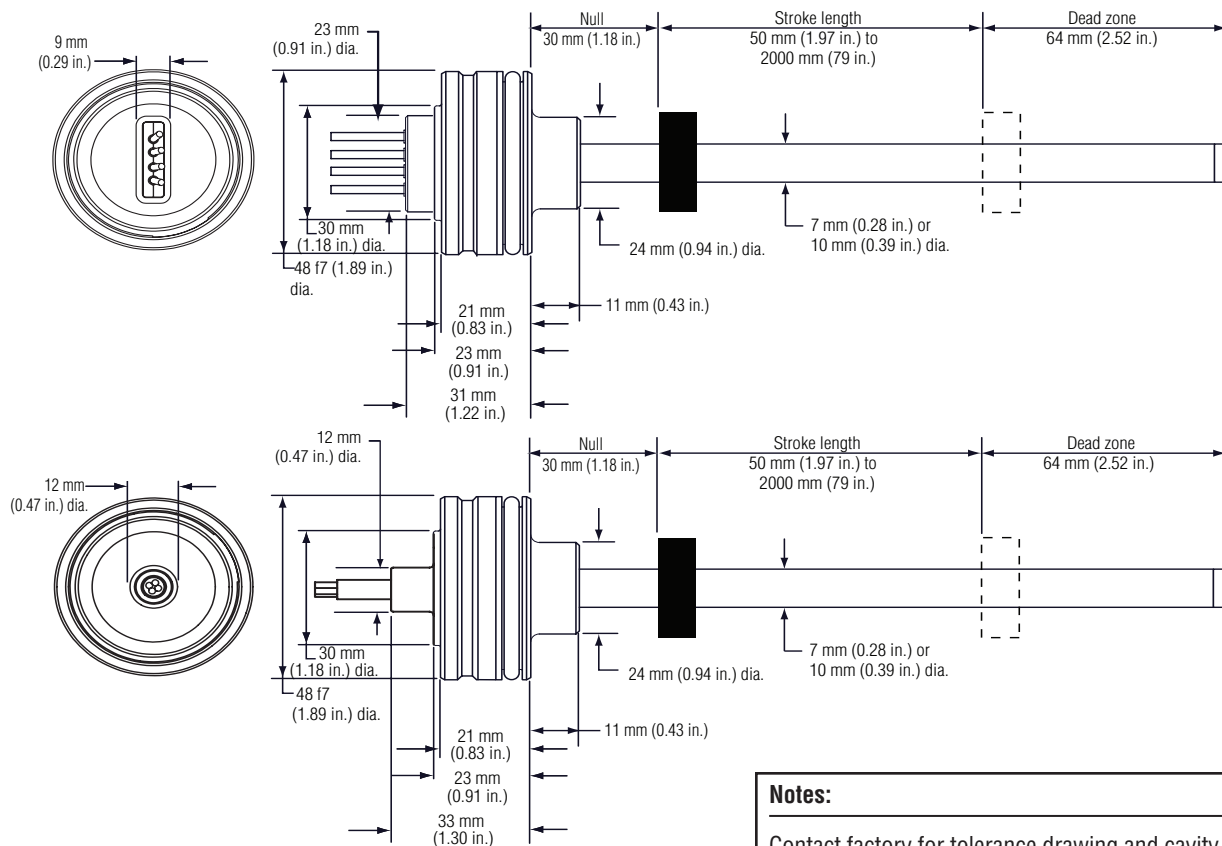

Notes:
Contact factory for tolerance drawing and cavity detail.

M-Series Model MH Digital Sensor installation, wiring examples and magnets

The robust Temposonics Model MH sensor's new stainless-steel position sensor is designed for direct stroke measurement in standard compact hydraulic cylinders. The Temposonics Model MH sensor can be installed from the head side or the rod side of the cylinder depending on the cylinder design.

Sensor installation

The method of installation is entirely dependent on the cylinder design. While the most common method of installation is from the rod side of the cylinder, installation from the head side of the cylinder is also possible. In both installation methods, the sensor seals the cylinder by using an O-Ring and backup ring which is installed on the sensor housing.

Temposonics Model MH sensor installation examples

Rod-side installation

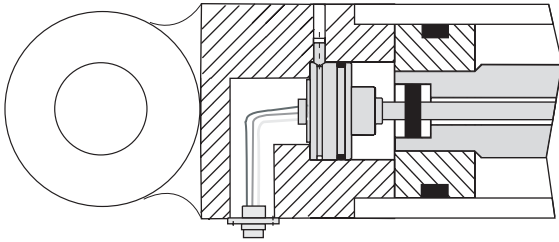

Cylinder head, side installation

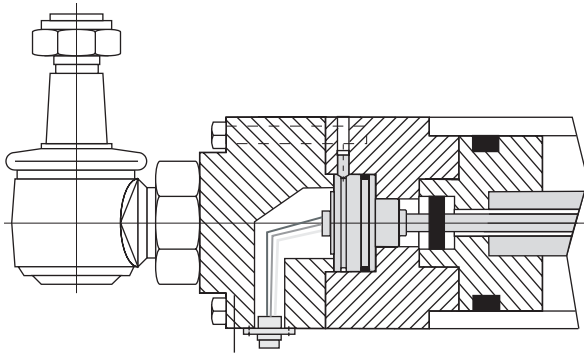

**Retaining screw with set screw DIN 914
M5 x 10 maximum torque 0.5 Nm
(0.369 lbf-ft. / 4.43 lbf-in.) or
UNF/UNC equivalent**

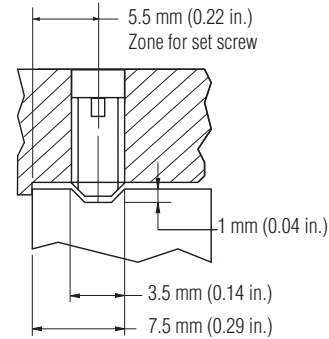

Detail flange housing

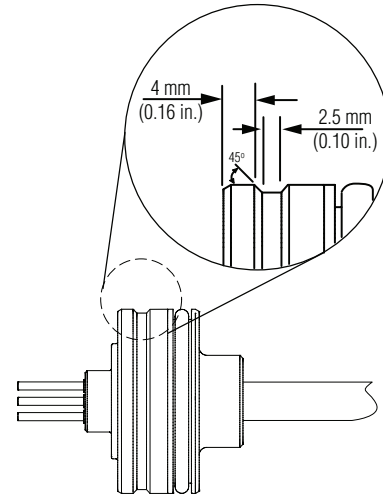

Wiring diagram (standard configuration)

Wire color	Signal	M12 Pin position
Green	Position output	4
Brown	12/24 Vdc	2
White	DC ground	3
Yellow	N/C	1

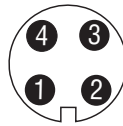

Position magnets

Part no. 201542-2

Temperature:
-40°C (-40 °F) to
105 °C (221 °F)
Material: Ferrite PA

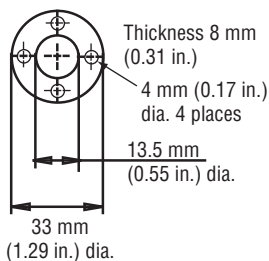

Part no. 400633

Magnet spacer
(use with magnet
part no. 201542-2)

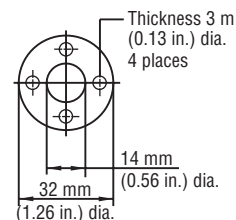

Part no. 400533

Temperature:
-40°C (-40 °F) to
105 °C (221 °F)
Material: Ferrite PA

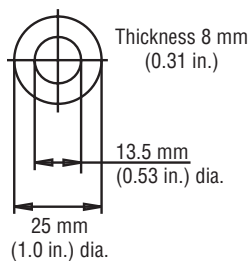

Part no. 401032

Temperature:
-40°C (-40 °F) to
105 °C (221 °F)
Material: Ferrite PA

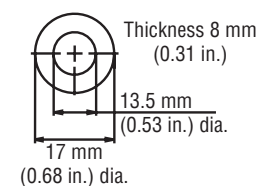

M-Series Model MH Digital sensor How to order and accessories

When placing an order, build the desired model number using the model number guide (right). If you have any questions about how to apply a model MH position sensor to your specific application, please contact MTS Applications Engineering.

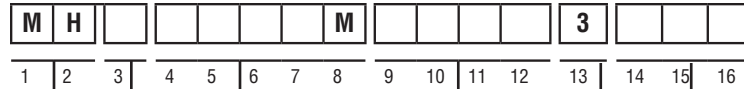

- SENSOR MODEL**
Hydraulic rod-style
48 mm (1.89 in.) dia. housing
- MH** =
- PRESSURE PIPE**
10 mm (0.39 in.) diameter
7 mm (0.28 in.) diameter
- C** =
D =
- STROKE LENGTH (order length)**
Millimeters 50 mm to 2000 mm (1.97 in. to 79 in.)
in 5 mm (0.19 in.) increments
- **M** =
- CONNECTION TYPE**
- N** --- = Integral "single wires", each conductor is 0.5 mm² (20 AWG)
Wire lengths:
10 = 100 mm (3.94 in.) length
20 = 200 mm (7.07 in.) length
30 = 300 mm (11.81 in.) length
Wire length: first digit x 100 mm / second digit x 10 mm
- Wire termination:
A = Pigtail (stripped conductors)
(Note: For wire termination, consult factory)
- E** = M12 integrated connector M12x1 for MH-Analog and MH PWM, A-polarization, 4-pin 4-wires, PIN1-N.C. - yellow, PIN2 - supply-brown, PIN3 - ground-white, PIN4 - signal-green.
- T** -- = Cable exit:
4 conductor / cable; Integral PUR cable, pigtailed, 4 cables, shielded
Cable length (first digit x 1m., second digit x 0.1 m.)
10 = 1.0 m. length (standard, all other lengths require minimum order quantities;
0.5 m. min. to 9.9 m. max.; 0.1 m. increments)
- Wire termination:
A = Pigtail (stripped conductors)
(Note: For wire termination, consult factory)
- 3** = **INPUT VOLTAGE**
+ 12/24 Vdc
- P** -- = **OUTPUT**

First Digit	
Span Range	Index
5-95%	A
10-90%	B
15-85%	C
20-80%	D
25-75%	E

Second Digit	
Span Range	Index
50Hz	A
60Hz	B
100Hz	C
200Hz	D
300Hz	E
400Hz	F
500Hz	G

Accessories	
Description	Part no.
Ring magnet	201542-2
Ring magnet	400533
Ring magnet	401032
Magnet spacer (use with magnet part no. 201542-2)	400633
M12 Connector Flange	253769



Part Number: 03-08 551119 Revision A
MTS and Temposonics, and are registered trademarks of MTS Systems Corporation.

All other trademarks are the property of their respective owners.
All Temposonics sensors are covered by US patent number 5,545,984. Additional patents are pending.
Printed in USA. Copyright © 2008 MTS Systems Corporation. All Rights Reserved in all media.



UNITED STATES
MTS Systems Corporation
Sensors Division
3001 Sheldon Drive
Cary, NC 27513
Tel: (800) 633-7609
Fax: (919) 677-0200
(800) 498-4442
www.mtssensors.com
sensorsinfo@mts.com

GERMANY
MTS Sensor Technologie
GmbH & Co. KG
Auf dem Schüffel 9
D - 58513 Lüdenscheid
Tel: +49 / 23 51 / 95 87-0
Fax: +49 / 23 51 / 56 491
www.mtssensor.de
info@mtssensor.de

JAPAN
MTS Sensors Technology
Corporation
Ushikubo Bldg.
737 Aihara-cho, Machida-shi
Tokyo 194-0211, Japan
Tel: +81 (42) 775 / 3838
Fax: +81 (42) 775 / 5516
www.mtssensor.co.jp
info@mtssensor.co.jp